



Contents

1. SCOPE	2
2. INSTALLATION	2
3. VALVE OPERATION	3
4. DISASSEMBLY	3
5. ASSEMBLY	4
6. REPAIR KITS	5
7. BILL OF MATERIALS	6

1. SCOPE

1.1. CAUTION

- 1.1.1. For your safety, read this manual before installation or service.
- 1.1.2. Before installing or servicing, please ensure the line pressure has been relieved and any hazardous fluids have been drained or purged from the system.
- 1.1.3. Ensure that all Lockout and Tagout procedures for the system have been properly implemented.

1.2. USE

- 1.2.1. Maximum results and long life of valves can be maintained under normal working conditions and according with pressure/ temperature ratings and corrosion data chart.

2. INSTALLATION

2.1. GENERAL INFORMATION FOR INSTALLATION

- 2.1.1. The valve can be installed in any position on the pipeline.
- 2.1.2. Before installation of the valve, the pipe must be flushed clean of dirt, burrs, and welding residue, or the seats and ball surface will be damaged. The pipe must be free from tension and in proper alignment. Check to ensure that all connections are free from defects.

2.2. INSTALLATION OF THREADED VALVES

- 2.2.1. Use conventional sealant, such as hemp core, Teflon, etc. on threads. Apply wrench only on the hexagon of the valve ends. Tightening by using the valve body or lever can seriously damage the valve. In some applications, screwed valves are back welded on site. These valves must be treated as per instructions for the weld end valves before back welding.

2.3. INSTALLATION OF WELDED ENDS

- 2.3.1. Tack weld the valves on the pipe in four points on both end caps.
- 2.3.2. With the valve in the open position, (lever to be parallel to the axis of the pipe), remove all the body bolts except one. Loosen the nut on the remaining bolt. Swing the body outside the pipe. Finish welding both end caps on the pipe.
- 2.3.3. When cooled down, clean both end caps and body surface.
- 2.3.4. Swing the body back in position and replace the body bolts. Tighten all nuts slightly. This operation is very important to keep the body and end caps perfectly parallel, thus preventing distortion of end caps. Tighten body bolts evenly (see section 5.5). Make sure that maximum tightening torque is observed. Check proper operation of the valve.

2.4. INSTALLATION OF EXTENDED SOCKET WELD ENDS

- 2.4.1. If welded properly, extended socket weld ends may be installed without disassembly of the valve. The ends have an integrated heat sink that is designed to assist in the dispersion of heat. This will aid in preventing damage caused by overheating of the polymeric components. See the 55-Series catalog for temperature ratings of the polymeric components that shall not be exceeded. When welding, the valve shall be in the fully open position to allow for thermal expansion and heat dispersion. It is recommended that an ASME Section IX BPVC procedure be followed by a certified welder.

3. VALVE OPERATION

3.1. MANUAL

3.1.1. HANDLE

- 3.1.1.1. To OPEN the valve, turn the handle counterclockwise until the handle is parallel with the pipeline and the handle has contacted the handle stop.
- 3.1.1.2. To CLOSE the valve, turn the handle clockwise until the handle is perpendicular with the pipeline and the handle has contacted the handle stop.
- 3.1.1.3. A handle lock is incorporated into the handle. To use, slide the lock into the mounting pad, in the full open or full closed position. Insert an appropriate size lock or hasp into the handle. If it can be performed safely, try to turn the handle to ensure that the valve has been locked properly.

3.1.2. GEAR

- 3.1.2.1. To OPEN the valve, turn the handle wheel counterclockwise. The indicator will be pointing to the open position and stop rotating when fully opened. The flow can be adjusted by stopping the indicator anywhere between open and close.
- 3.1.2.2. To CLOSE the valve, turn the handle wheel clockwise. The indicator will be pointing to the close position and the hand wheel will stop rotating when fully closed. The flow can be adjusted by stopping the indicator anywhere between open and close.

3.2. AUTOMATED

- 3.2.1. A-T Controls 55 Series Ball Valves can be mounted with quarter turn actuators. Valves with actuators shall be checked for proper valve stem alignment. Angular or linear misalignment may result in high operational torque and unnecessary wear on the valve stem. See the actuator IOM for information on operating the actuator.

4. DISASSEMBLY

!!! WARNING !!!

CAUTION, FLUIDS CAN BE TRAPPED IN THE BODY OF THE VALVE, POSSIBLY UNDER HIGH PRESSURE. FOR YOUR SAFETY, IT IS IMPORTANT THAT PRECAUTIONS ARE TAKEN BEFORE REMOVAL OF THE VALVE FROM THE LINE OR ANY DISASSEMBLY.

- 4.1. Remove actuator or gear if equipped.
- 4.2. Care should be taken to not damage the surface finish of the valve components,
- 4.3. Remove the ends (2) from the body (1) by removing the body bolts (14), body nuts (17), and lock washers (18).
- 4.4. Remove the seats (8) and body gaskets (13) from both sides of the body (1). Once removed, with the valve in the fully closed position, the ball (3) should slide freely out of the body (1).
- 4.5. If equipped, remove the handle nut (21), handle (7), and the handle stop assembly (15).

Installation & Maintenance Manual

- 4.6. While holding the stem (4) stationary, remove the packing nut (5). Once removed, the locking saddle (12), Belleville washers (6), and the packing bushing (9) should be free to remove.
- 4.7. While holding the bottom of the stem (4), push the stem (4) through the inside of the valve body (1).
- 4.8. Remove the packing set (10) and the thrust washer (11).
- 4.9. Inspect all components for damage and, if necessary, clean or replace.

5. ASSEMBLY

- 5.1. Care should be taken to not damage the surface finish of the valve components.
- 5.2. Place thrust washer (11) on the stem (4) and install it by going through the body (1). Insert V-style packing set (10) over stem (4) with the V pointing away from the valve (see Bill of Materials for correct orientation).
- 5.3. Install the packing gland (10), Belleville washers (6), the locking saddle (12), and the packing nut (5). While holding the stem (4), tighten the packing nut (5) to the torque listed in the Fastener Torque Chart. Tighten further if needed in order to be able to place the locking saddle (12) over the packing nut (5).
- 5.4. Ensure the stem (4) is in the closed position with the body tang parallel with the flow of the valve. Insert a seat (8) and body gasket (13) in one side of the body (1). Carefully slide the ball (3) into the body (1) and insert the other seat (8) and body gasket (13).
- 5.5. Assemble ends (2) onto body (1). Insert all body bolts (14), body nuts (17) and lock washers (18) into valve and tighten to finger tight, making sure that the ends (2) are flat against the body (1). Tighten all body bolts (on both sides for 2-1/2" thru 4") from the nut (17) to 50% of the max bolt torque in a star pattern. Check each body bolt (14) torque and tighten a final time to the max torque of the body bolts. It is acceptable for the torque to relax slightly over time due to relaxation of the polymer components, but the valve will still seal properly. If leakage is detected, repeat the steps for tightening the body bolts (14).
- 5.6. If required, assemble the locking device (20), handle stop (15), handle (7), and the handle nut (21).

Fastener Torque Chart			
Valve Size	50% of Max Body Bolt Torque (In-lbs.)	Max Torque of Body Bolts (In-lbs.)	Torque of Stem Nut (In-lbs.)
1/4"	45	90	61
3/8"	45	90	61
1/2"	58	115	78
3/4"	63	125	78
1"	70	140	113
1-1/4"	110	220	113
1-1/2"	160	320	148
2"	220	440	148
2-1/2"	350	700	191
3"	400	800	191
4"	400	800	217

6. REPAIR KITS

Repair kits are available to replace all soft goods. See Bill of Materials for components that are included in the repair kits.

7. BILL OF MATERIALS

NO.	PART NAME	QTY	REPAIR KIT
1	BODY	1	
2	END CAP	2	
3	BALL	1	
4	STEM	1	
5	STEM NUT	2	
6	BELLEVILLE WASHER	2	
7	HANDLE	1	
8	SEAT	2	X
9	GLAND BUSHING	1	
10	GLAND PACKING	1^	X
11	THRUST WASHER	1	X
12	LOCK SADDLE	1	
13	JOINT GASKET	2	X
14	BODY BOLT	*	
15	STOP BOLT	1	
16	HANDLE SLEEVE	1	
17	BODY NUT	#	
18	LOCK WASHER	#	
19	STEM WASHER	1	
20	HANDLE LOCK	1	
21	HANDLE NUT	1	
^ PACKING SET			
* 1/4" THRU 3" QTY=4 PCS			
* 4" QTY= 6 PCS			
# 1/4" THRU 2" QTY= 4 PCS			
# 2-1/2" THRU 3" QTY= 8 PCS			
# 4" QTY= 12 PCS			

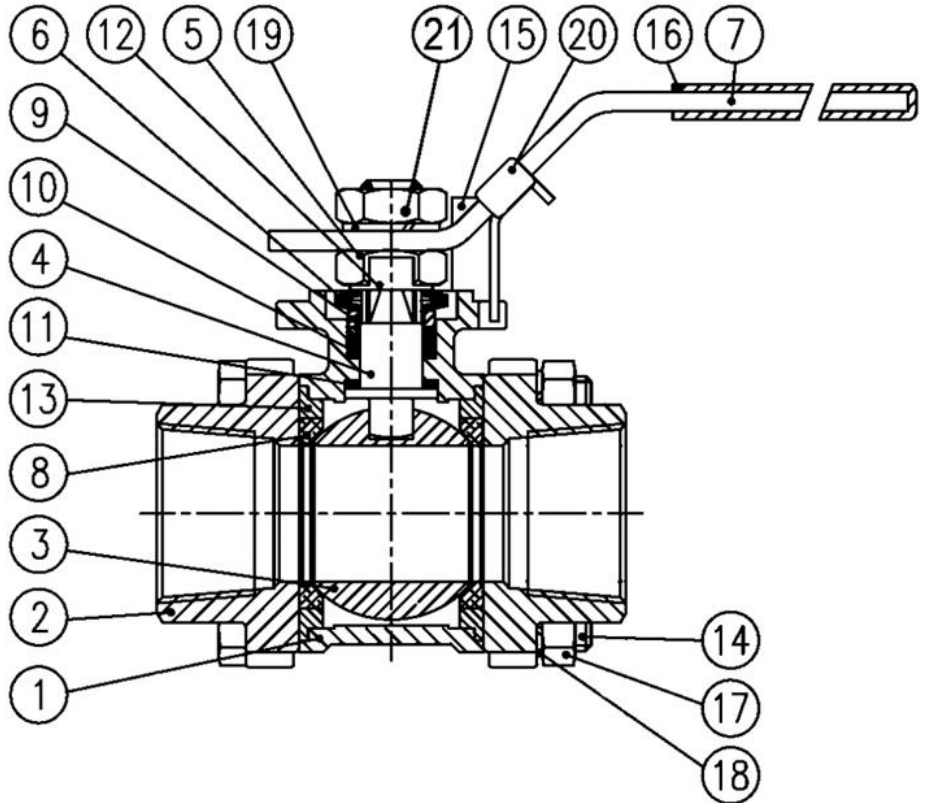

A-T Controls product, when properly selected, is designed to perform its intended function safely during its useful life. However, the purchaser or user of A-T Controls products should be aware that A-T Controls products might be used in numerous applications under a wide variety of industrial service conditions. Although A-T Controls can provide general guidelines, it cannot provide specific data and warnings for all possible applications. The purchaser / user must therefore assume the ultimate responsibility for the proper sizing and selection, installation, operation, and maintenance of A-T Controls products. The user should read and understand the installation operation maintenance (IOM) instructions included with the product and train its employees and contractors in the safe use of A-T Controls products in connection with the specific application.

While the information and specifications contained in this literature are believed to be accurate, they are supplied for informative purposes only. Because A-T Controls is continually improving and upgrading its product design, the specifications, dimensions and information contained in this literature are subject to change without notice. Should any question arise concerning these specifications, the purchaser/user should contact A-T Controls.

For product specifications go to <https://a-tcontrols.com/Downloads/>

A-T Controls, Inc. • 9955 International Boulevard, Cincinnati, OH 45246 • Phone: (513) 530-5175 • Fax: (513) 247-5462 • www.atcontrols.com